

A : Link Unit

B : Bottle Holders x 2

C : 4 x M8 Hex Head Bolts (not shown – THESE BOLTS ARE PRE-FIXED INTO THE WASH UNIT ARMS AND NEED REMOVING BEFORE FIXING LINK INTO PLACE)

REM

T: 01282 619977
F: 01282 619617

Paragon Wash Unit Link

04523

Component Details

Date: 04/05/2010 – Edition 1

Produced by: PP

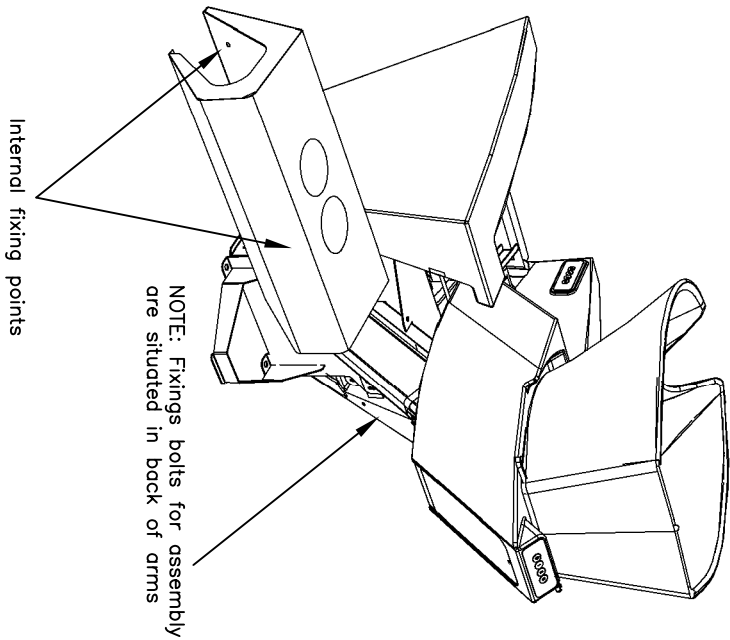

1. Carefully unwrap components and ensure all pieces are in order. When Paragon Wash Unit(s) is correctly in position fix link unit (A) into position by using Fixing Bolts (C) provided from the inside of the unit onto the rear of the wash unit arm.

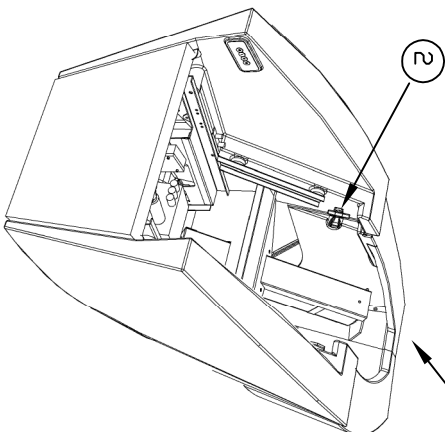
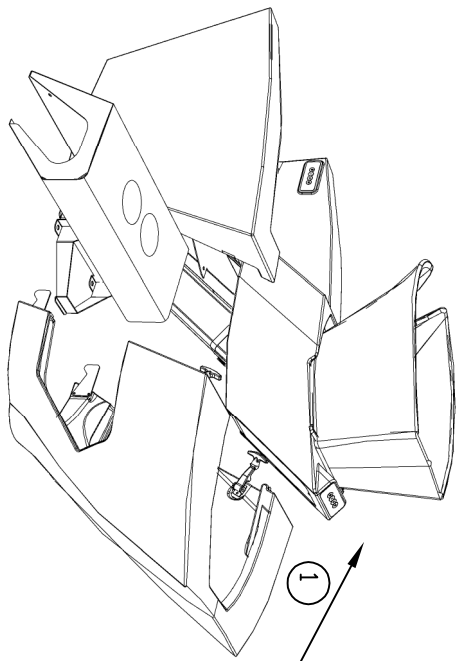

2. Hook Rear Cover over rear of chassis and link [1] (NOTE, base section may need squeezing together to slot in). Fasten upper rubber clips to secure cover [2]

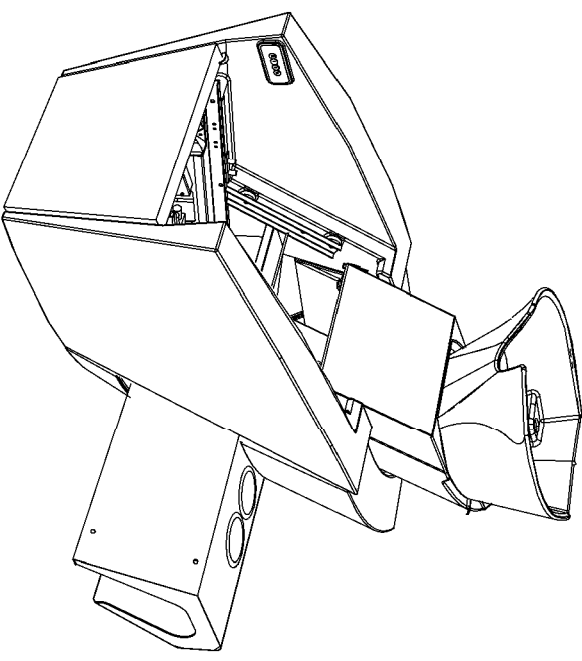

3. Carefully place Bottle Holders (B) into link unit (A). Repeat these fixing procedures for multiple units.
When complete continue wash unit assembly.

PREMI

T: 01282 619977
F: 01282 619617

Paragon Wash Unit Link
04523

Assembly Instruction Sheet
Date: 04/05/2010 – Edition 1
Produced by: PP